

aiwa

**OPERATING INSTRUCTIONS
INSTRUCCIONES DE MANEJO
MODE D'EMPLOI**

CS-P77

**STEREO RADIO CASSETTE RECORDER
RADIO-CASSETTE ESTEREOFÓNICO**

English: See page 2.

En

Español: Ver la página 8.

E

Français: Voir page 14.

F

WARNING

TO REDUCE THE RISK OF FIRE OR ELECTRIC SHOCK, DO NOT EXPOSE THIS APPLIANCE TO RAIN OR MOISTURE.

OWNER'S RECORD

For your convenience, record the model number (you will find it at the bottom of the unit) and serial number (you will find it in the battery compartment) in the space provided below. Please refer to them when you contact your AIWA dealer in case of difficulty.

Model No. Serial No.

Precautions

Power sources

Use on batteries or AC house current, as specified in the Operating Instructions and marked on the unit.

On placement

- Do not use the unit in places which are extremely hot, cold, dusty or humid. In particular, do not keep the unit:
 - in a high humidity area such as a bathroom
 - near a heater
 - in an area exposed to direct sunlight (e.g., inside a parked car, please be careful because it may become extremely hot)
- Place the unit on a flat, even surface.

For safety

Take care that objects or liquids do not get inside the unit.

When not in use

Disconnect the AC adaptor and remove all the batteries if the unit will not be used for a long period of time. When the cord is plugged in, a small amount of current continues to flow to the unit even when the unit is not being used.

If an erroneous display or malfunction occurs

Press the reset hole (RESET) with a thin stick or a similar tool.

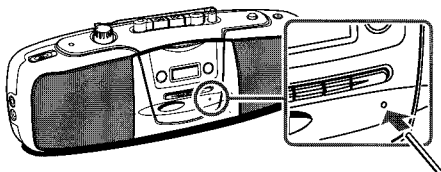

Power Supply

Using on batteries

Open the lid of the battery compartment on the rear and insert four R6P (size AA) batteries, not supplied, with the \oplus and \ominus marks correctly aligned. Then close the lid.

- Before using on batteries, disconnect the AC adaptor from the DC 6V jack. Battery power is cut off automatically when the AC adaptor is connected.

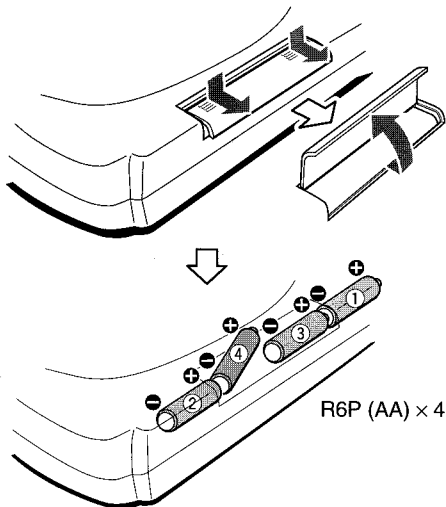

The batteries need to be replaced when:

The OPE/BATT indicator becomes dim, the tape speed slows down, volume decreases, or sound is distorted during operation.

Notes on batteries

- Do not mix different types of batteries or old batteries with new ones.
- Never recharge the batteries, apply heat to them or take them apart.
- Remove dead batteries.

If liquid leaks from the batteries, wipe thoroughly to remove.

Using on AC house current

Connect the supplied AC adaptor as illustrated below.

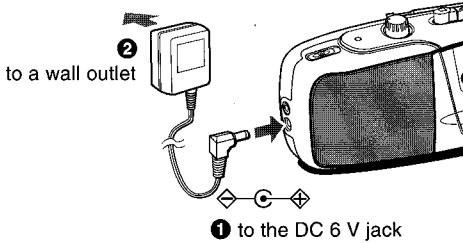

Notes on AC adaptor

- Use only the supplied AC adaptor.
- After use, disconnect the AC adaptor. When disconnecting from the unit, grasp the adaptor and not the cord itself.
- Do not forcibly bend the cord or place heavy objects on it.
- Never handle the AC adaptor with wet hands, as this could result in fire or shock.

Backup function

The settings of the clock, radio and timer are maintained for a few minutes after removing the batteries or disconnecting the AC adaptor. Replace the batteries while the backup function is activated.

Specifications

Tuner section

Frequency range, antenna — FM: 87.5 - 108.0 MHz
Rod antenna, AM: 530/531 - 1,710/1,602 kHz (10/9 kHz step) Ferrite bar antenna

Deck section

Track format — 4 tracks, 2 channels / Frequency range — Normal tape: 50 - 8,000 Hz (EIAJ) / Recording system — AC bias / Erasing system — Magnet erase / Heads — Recording/playback head (1), Erasure head (1)

General

Speaker — 58 mm cone type (2) / Output — Headphones jack (stereo mini-jack) / Power output — 0.5 W + 0.5 W (EIAJ 4 ohms, T.H.D. 10%) / Power requirements — DC 6 V using four size AA (R6P) batteries, Domestic AC power using the supplied AC adaptor / Dimensions — 280 (W) × 106 (H) × 61 (D) mm (11 1/8 × 4 1/4 × 2 1/2 in.) / Weight — 650 g (1 lb. 7 oz.) (excluding batteries) / Accessories — AC adaptor (1)
<AC adaptor AC-D602 U>
Rated input — AC 120 V, 60 Hz / Rated output — DC 6 V, 500 mA

Specifications and external appearance are subject to change without notice.

COPYRIGHT

Please check the copyright laws relating to recordings from discs, radio or external tape for the country in which the machine is being used.

Maintenance

To clean the cabinet

Use a soft cloth lightly moistened with mild detergent solution. Do not use strong solvents such as alcohol, benzine or thinner.

To clean the heads

- When the tape heads are dirty;
- high frequency sound is not emitted
 - the sound is not adequately high
 - the sound is off-balance
 - the tape cannot be erased
 - the tape cannot be recorded on

After every 10 hours of use, clean the tape heads with a head cleaning cassette.

Use separately sold dry-type or wet-type cleaning cassette.

Refer to the instructions of the cleaning cassette for details.

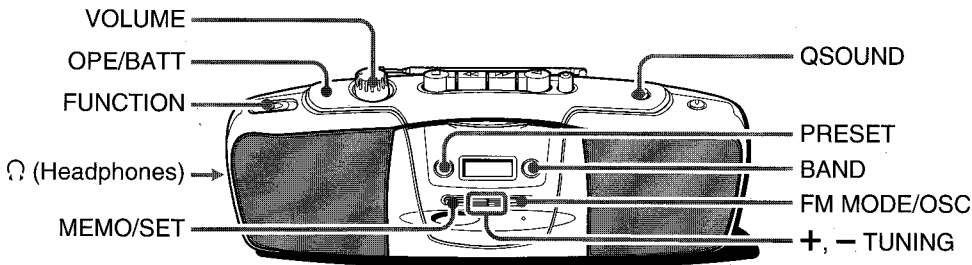

GENERAL

QSOUND system

This system provides a rich, three dimensional sound area. You can enjoy more enhanced sound.

Press QSOUND.

- At higher volumes, turning QSOUND on may cause sound distortion. In this case, turn the volume down.

To listen with the headphones, connect headphones with a stereo mini plug to the Ω (Headphones) jack.

To turn off the unit, set FUNCTION to TAPE/RADIO OFF to turn off the OPE/BATT indicator.

A SETTING THE CLOCK

Insert the batteries or connect the AC adaptor. The clock display flashes.

- 1** Set FUNCTION to TAPE/RADIO OFF.
- 2** Keep MEMO/SET pressed for 1 second until the "hour" display flashes.



- 3** Press +, - TUNING to set the hour and then press MEMO/SET.
- 4** Press +, - TUNING to set the minute and then press MEMO/SET.

If the clock display flashes

This is caused by a power interruption. Set the clock again.

B TUNER OPERATION

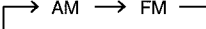
- 1 Set **FUNCTION** to **RADIO**.
- 2 Select a band with **BAND**.

- 3 Select a station with **+**, **- TUNING**.
During FM stereo reception, "ST" is displayed.
- 4 Turn **VOLUME** to adjust the sound.

For better reception

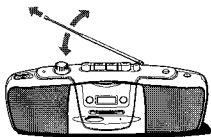
FM



Extend the rod antenna and orient it for the best reception.

AM

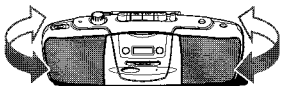

The antenna is inside the unit. Position the unit for the best reception.

For quick tuning

Keep **+**, **- TUNING** pressed until the tuner starts searching for a station. When a station is tuned to, the search stops.

If the broadcast signal is weak, it does not stop. To stop the search manually, press **+** or **-**.

FM MODE/OSC

- If an FM stereo broadcast contains noise, press the button so that "MONO" is displayed. Noise is reduced, although reception is monaural. To restore stereo reception, press the button again.
- If a high-pitched sound is heard during recording from AM, press the button repeatedly until noise is reduced.

To change the AM tuning interval

The default setting of the AM tuning interval is 10 kHz/step. If you use this unit in an area where the frequency allocation system is 9 kHz/step, press **BAND** while pressing **MEMO/SET** to change the tuning interval.

When the AM tuning interval is changed, the preset stations are cleared.

NOTE

If the unit picks up noise from other electrical appliances nearby, like a TV or fluorescent lights, move the unit away.

PRESETTING STATIONS

Stations are automatically scanned once through the receivable frequency range. Preset them as follows.

- 1 Select a band with **BAND**.
- 2 Keep **MEMO/SET** pressed for 1 second until "PRESET" flashes in the display.

Scanning starts, and when a station is tuned to, scanning stops. The tuned station is heard for 10 seconds.

- 3 Within 10 seconds, press **MEMO/SET** to store the station.

Scanning starts again. Every time a station is scanned, press **MEMO/SET** within 10 seconds. Stations are stored in the received order and scanning stops after 7 stations are preset.

- To skip a tuned station, do not press **MEMO/SET**.
- If the broadcast signal is weak, scanning does not stop.

To listen to preset stations, select a band then press **PRESET** repeatedly.

To preset a station manually

You can preset stations in the desired order.

- 1 Select a band with **BAND** and tune to a station with **+**, **- TUNING**.
- 2 Press **MEMO/SET** once. "PRESET" flashes in the display for 5 seconds.
- 3 Within 5 seconds, press **PRESET** repeatedly to select a preset number and press **MEMO/SET** to store the station.
To preset more stations, repeat the procedure from the beginning.

En

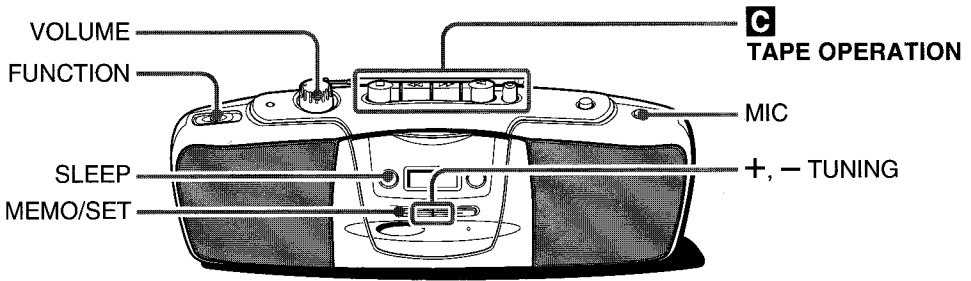

C TAPE OPERATION

Use Type I (normal) tapes only.

PLAYING A TAPE

- 1 Set **FUNCTION** to **TAPE/RADIO OFF**.
- 2 Place your finger on the top of the cassette holder and pull it, then insert a tape with the exposed side up and the side to be played facing out.

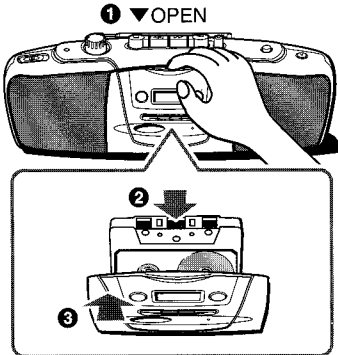

- 3 Press **◀ PLAY** to start play.
- 4 Turn **VOLUME** to adjust the sound.

■ **STOP** - Stops play.

◀◀ **F FWD** / ▶▶ **REWIND**

- Fast forwards/rewinds. To stop the winding, press ■ **STOP**.

When the end of a tape is reached, press ■ to release ◀◀, ▶▶.

- Cues/reviews the tape during play. Keep ◀◀ or ▶▶ pressed and then release it.

RECORDING

Note that recording is done on only one side of the tape.

- 1 Insert a tape with the side to be recorded facing out.
- 2 Tune to a station.
Refer to "TUNER OPERATION".
- 3 Press ● **REC** to start recording.
◀ **PLAY** is pressed simultaneously.

To stop recording, press ■ **STOP**.

To record from built-in microphone, set **FUNCTION** to **TAPE/RADIO OFF** and start recording. Orient the microphone (**MIC**) to the sound source.
Recording is monaural.

To prevent accidental erasure, break off the plastic tabs on the cassette tape with a screwdriver or other pointed tool after recording.

To record on the tape again, cover the tab openings with adhesive tape, etc.

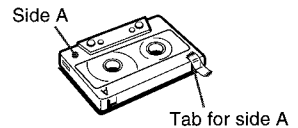

D SETTING THE TIMER

The radio can be automatically turned on at the designated time every day and turned off after 60 minutes.

Make sure the clock is set correctly.

- 1 Tune to a station and adjust the volume.**
Refer to "TUNER OPERATION".
- 2 Set FUNCTION to SLEEP/TIMER, then keep MEMO/SET pressed for 1 second until "hour" display and "-" flashes.**



- 3 Within 10 seconds, set the timer-on time.**

Follow steps 3 to 4 of "SETTING THE CLOCK". When the setting is completed, the power automatically turns off. The display switches to the current time and "-" remains in the display.

If flashing stops during operation

Repeat the procedure from step 2.

To cancel the timer

Set the FUNCTION to TAPE/RADIO OFF. Set the switch to SLEEP/TIMER to resume the timer setting.

To check the timer-on time

Set FUNCTION to any position other than SLEEP/TIMER, then set it to SLEEP/TIMER again. The designated time will flash for 5 seconds in the display.

Using the unit while the timer is set

You can use the unit normally after setting the timer.

After use, tune to the station which you wish to hear when using the timer and set the volume again. Then, set FUNCTION to SLEEP/TIMER.

NOTE

- The timer will not work if the power is turned on.
- You cannot tune to another station when the unit has been turned on by the timer.

E SETTING THE SLEEP TIMER

The radio can be automatically turned off after 60 minutes.

- 1 Tune to a station.**
Refer to "TUNER OPERATION".
- 2 Set FUNCTION to SLEEP/TIMER.**
- 3 Keep SLEEP pressed for 1 second until "60" is displayed.**



To cancel the sleep timer

Press SLEEP. Switching FUNCTION also cancels the sleep timer.

NOTE

This equipment has been tested and found to comply with the limits for a Class B digital device, pursuant to Part 15 of the FCC Rules. These limits are designed to provide reasonable protection against harmful interference in a residential installation.

This equipment generates, uses, and can radiate radio frequency energy and, if not installed and used in accordance with the instructions, may cause harmful interference to radio communications.

However, there is no guarantee that interference will not occur in a particular installation. If this equipment does cause harmful interference to radio or television reception, which can be determined by turning the equipment off and on, the user is encouraged to try to correct the interference by one or more of the following measures:

- Reorient or relocate the receiving antenna.
- Increase the separation between the equipment and receiver.
- Connect the equipment into an outlet on a circuit different from that to which the receiver is connected.
- Consult the dealer or an experienced radio/TV technician for help.

CAUTION

Modifications or adjustments to this product, which are not expressly approved by the manufacturer, may void the user's right or authority to operate this product.

AIWA CO.,LTD.

Printed in Hong Kong